



packaging machinery

**Good Packed Good Sold..!  
İyi Ambalaj Sattırır..!**



**Packaging, Cartoning and Bailing Machines  
Paketleme, Kolileme ve Balyalama Makinaları**



[www.tamtas.net](http://www.tamtas.net)





#### Vertical Packaging Machines

The vertical packaging machines are manufacturing in various types according to the pack sizes, pack types and the products they are packing. They also are manufacturing in 4 different models according to the pack sizes they produce such as ODM100, ODM400, ODM600 and CMP444. The filling systems for the vertical packaging machines change according to the product variety; The granular types of products like dried fruits, nuts, cips, biscuits and wafers, chocolates, and pulses, etc are packed with electrical combination weighers or volumetric filling systems. The powder type of products like coffee, coffee creme, cacao additives, mix flours, spices, pesticides, etc are packed with screw dosing systems.

#### Dikey Paketleme Makinaları

Dikey paketleme makinaları yaptıkları paket büyüklüklerine göre, paketleme kapasitelerine göre, paket tiplerine göre ve paketledikleri ürün çeşitlerine göre değişik tiplerde üretilmektedir. Dikey Paketleme makinaları ürettikleri paket boyutlarına göre ODM100, ODM400, ODM600 Ve CMP444 olmak üzere 4 değişik modelde üretilmektedir. Dikey Paketleme makinalarının paketlenen ürün çeşitlerine göre, dolum sistemleri de değişmektedir. Kuruyemişler, Cipsler, bisküvi ve gofretler, çikolatalar, bakliyat çeşitleri gibi taneli ürünler elektronik terazili dolum sistemleri veya volumetrik dolum sistemleri ile paketlenmektedir. Kahve, krema, kakao katkı maddeleri mix unlar, baharatlar, tarım ilaçları vb. toz ürünler vidalı dolum sistemleri ile paketlenmektedir.

#### Doypack Type Packaging Machines

Doypack type packaging machines manufacturing in two different types according to their working principles and manufacturing in four different types according to their filling systems. Model HT 85-200 packaging machine can pack powder, granular and / or liquid products in pre-made pouches. Model DB/S 70-105 packaging machine transforms the packaging material in bobbin into doypack shaped packs and fills powder, granular and/or liquid products with optional zipper and spout applications. In doypack type packaging machines granular products like dried fruits, nuts, cips, biscuits and wafers, chocolates, chocolate coated nuts and coffees (gold type), etc fill with electrical combination weighers and liquid or semi-liquid products like ketchup, mayonnaise, chocolate cremes, liquid soaps, etc fill with liquid pump filling system the powder products like powder coffee, milk powder, spices, etc fill with screw dosing systems.

#### Doypack Tip Ambalaj Makinaları

Doypack tip ambalaj makinaları çalışma prensiplerine göre iki değişik tipte, dolum sistemine göre de dört değişik üretilmektedir.

HT 85-200 Model makine hazır haldeki doypack tip paketler tam olarak toz, granül veya likit ürünler dolumu yapabilmektedir.

DB/S 70-105 Model makine bobin halindeki ambalaj malzemesini doypack paket haline getirip isteğe göre zipper veya musluk takarak tam otomatik olarak toz, granül veya likit ürünler dolumu yapabilmektedir. Doypack tip paketleme makinaları kuruyemişler, cipsler, bisküvi ve gofretler, çikolatalar, drajeler, gold kahveler vb. granül ürünler elektronik terazili dolum sistemleri ile ketçap, mayonez, sıvı çikolatalar, sıvı sabunlar ve likit ürünler likit pompalı dolum sistemi ile, toz kahve, süt tozu, baharatlar vb. toz ürünler de vidalı dolum sistemleri ile paketlenmektedir.



#### OBM 130 Full Automatic Bailing Machine

The OBM130 is a Full Automatic Baling Machine; which is getting the ready bags that come out of one or several packaging machines, and packs the desired number of this bag into one group of bag. The Bailing Machine it's working from the roll and seal the pack from the top.

#### Tam Otomatik Balyalama Makinesi

OBM130 Tam otomatik balyalama makinesi; kendi hazırladığı balya poşetine bir veya birkaç paketleme makinesinden çıkan paketleri otomatik olarak alıp sıralayan ve poşet içine istenilen düzen, kat ve sayıda dolduran tam otomatik bir makinedir. Kendi bobin standında rulo halinde bulunan filmi büyük balya poşeti haline getirir içini doldurur ve üstünü kapatır.



#### OKM 500 FULL AUTOMATIC CARTONING MACHINES

The OKM500 It is a Full Automatic Cartonning Machine that packs and sorts automatically one or more packages and fills them into desired arrangement. It automatically getting the carton from the magazine opening, getting the certain shape, closing the bottom flaps, then sealing by tape. The machine also has a vibration system to fit packaging, with automatic adjustment systems that make product and size changes simple and fast, as well as a weighing system that identifies and separates missing or overweight cartons.

#### OKM 500 TAM OTOMATİK KOLİLEME MAKİNASI

OKM500 Tam otomatik kolileme makinesi; kendi hazırladığı kollere bir veya birkaç paketleme makinesinden çıkan paketleri otomatik olarak alıp sıralayan ve koli içine istenilen düzen, kat ve sayıda dolduran tam otomatik bir makinedir. Kendi magazininde açık pozisyonda istiflenmiş halde bulunan kolleri otomatik olarak alır, açar, altını koli bandı ile yapıştırır, içini doldurur ve üstünü koli bandı ile kapatır. Makine paketlerin koli içine sığabilmesi için vibrasyon sistemlerine, ürün ve ebat değişimlerini basit ve hızlı hale getiren otomatik ayar sistemlerine ve de eksik yada fazla gramajlı kollileri belirleyip ayıran tartım sistemine de sahiptir.



#### Shrink Wrapping Machines

The Shrink packaging machines are semi-automatic, full automated front-feed, and more other new different feed types are manufactured, can pack carton, pans, cans, glass bottles, jars, plastic bottles, plastic bottles in the food, chemical, cosmetic, textile and stationery products printed or polyethylene (PE) is used in the packaging wrapped with PVC or polyolefin film packaging.

#### Shrink Ambalaj Makinaları

Shrink ambalaj makinaları, koli, karton tava, teneke kutu, cam şişe, kavanoz, plastik şişe, pet şişe içindeki gıda, kimya, kozmetik, tekstil ve kırtasiye ürünlerinin baskılı veya baskısız polietilen (PE), PVC veya Poliolenin folyo ambalajlar ile sarılarak ambalajlanmasında kullanılmaktadır. Yan otomatik, önden beslemeli tam otomatik, yandan beslemeli tam otomatik olarak değişik tiplerde imal edilmektedir.



#### Vacuum Chamber Machines

The Vacuum packing machines has a various sizes depending on the usage and product in accordance with the vacuuming capacity and type. The table models are used retail points, by Butcher, deli meats, nuts aisles, etc And the industrial models are used in dairies, meat processing plants, aquaculture plants and etc.

#### Vakum Ambalaj Makinaları

Vakum ambalaj makinaları kullanılacakları yere göre ve vakumlama kapasitelerine göre değişik boyda ve tipte üretilmektedir. Kasap, şarküteri, kuruyemiş reyolları vb. perakende noktalarında tezgah üstü modeller, mandıralar, et işleme tesisleri, su ürünleri fabrikaları vb. sanayi tesislerinde koridor tip endüstriyel modeller kullanılmaktadır.





**CMP 444** Continuous Motion Packaging Machine  
Hareketli Yatay Çeneli Paketleme Makinesi

CMP 444 Servo Continuous Motion Packaging Machine is designed to get 130 packs/min for the weight range between 20gr – 1000gr , the size of the pack is 250\*340 mm in maximum, The packs shapes can be Pillow bag, Stand up bag. This machine is designed for the facilities who desire higher speed.

The volumetric filling system and the electronic weighing system are used for crystalized and granular products, The screw filling system is used for powder products. Also there is the liquid filling systems for liquid products

CMP 444 Hareketli yatay çeneli servolu dikey paketleme makinası yastık ,ve oturan paket yapmaktadır. Makinede 20 gr ile 1000 gr arası ürünler paketlenmektedir. Max paket ebadı 250\*340 mm dir. Yüksek hızda paketleme kapasitesi istenilen tesislerde kullanılmaktadır. Makinede Volumetrik dolum sistemi serbest akıcılığı olan kristalize ve granül ürünler, Vidalı dolum sistemi ile toz ürünler Elektronik terazili dolum büyük ebatlı ve kırılğan ürünler, likit dolum sistemi sıvı ürünler paketlenmektedir.

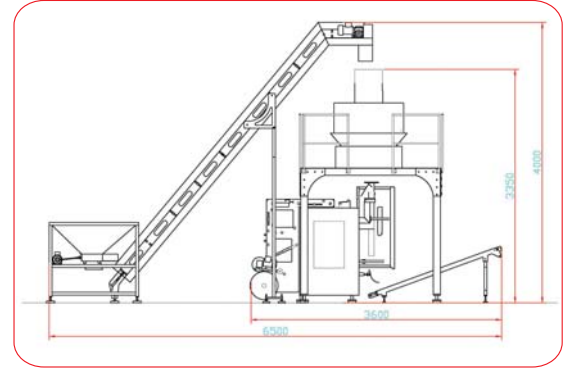

Technical Details Teknik Detay	CMP 444
Filling System / Dolum Sistemi	Electronic weighing system- Servo, Volumetric , Auger filler / Volumetrik, Vidalı, Çok kefeli terazili, Servo kontrollü terazili
Suitable for / Paketlenebilen ürünler	Cereals, nuts, dry fruits, chocolate, candy, chips, cookies, pasta, fruit, vegetables, frozen meat, coffee, tea etc. Kuruyemiş, şekerleme, bisküvi, çikolata, cipsler, kraker, jelly, makarnalar, kahve, krema vb. ürünler.
Filling Range / Gramaj Aralığı	20- 1000 gr
Shape of the Bag / Paket Tipleri	Pillow bag , Stand up bag / Yastık paket ve oturan paket
Packaging Speed / Paketleme Hızı	70-130 ppm / 70-130 pak/dakika
Type of Packaging Material / Ambalaj Malzemesi Cinsi	OPP, CPP, Pet, Alu, Metalize and other laminated films / Opp, Cpp, Pet, Alu, Metalize vb. laminasyonlu malzemeler
Min. Dimensions of the Bag / Min. Paket Eni ve Boyu	70 x 100 mm
Max. Dimensions of the Bag / Max. Paket Eni ve Boyu	260 x 400 mm
Max. Width of the Film / Max. Bobin Eni	550 mm
Inner Diameter of the Core / Bobin Makarası İç Çapı	76 mm
Max . Diameter of the Roll / Max. Bobin Çapı	500 mm
Dimensions of the Machine / Makine Ebatları	1500 x 2200 x 1700 mm
Weight of the Machine / Makine Ağırlığı	1.100-kg
Mechanic Structure / Mekanik Kontrol Sistemi	By servo / Üç eksen servo kontrollü
Pneumatic Systems / Pnömatik Sistem	Festo
Control System / Elektrik Sistemi	MITSUBISHI
Electricity Supply & Consumption / Elektrik Beslemesi ve Tüketimi	380 Volt AC / 7 KwH
Air Supply & Consumption / Hava Beslemesi ve Tüketimi	6 bar / 200 Lt / min.

**Vertical Packaging Machines  
With Auger (screw) Dosing System**

**Vidalı Dolum Sistemli Dikey Paketleme Makinaları**

Suitable for powders and similar fine products. A specific screw for each product, precisely doses the correct amount directly into the forming tube of the packaging machine. Controlled by SIEMENS PLC. The system can be easily dismantled for thorough cleaning.

Suitable for products like, Cocoa, Milk Powder, Spices, Salt, Powder Detergent, Instant Drinks, Coffee and etc....

Akıcılığı olmayan toz haldeki mamüllerin tam otomatik olarak paketlenmesinde kullanılmaktadır. Genellikle baharatlar, toz kahve, süt tozu, mix un, kremşanti, katkı maddeleri, tarım ilaçları vb. toz ürünlerin ambalajlanmasında kullanılır. İsteğe bağlı olarak, yastık paket, oturan paket ve quadro paket tiplerinde ambalajlama yapar.

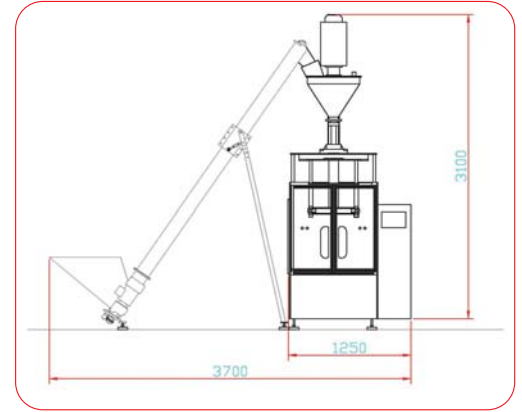

Technical Details Teknik Detay	ODM 100-V	ODM 400-V	ODM 600-V
Filling System / Dolum Sistemi	Auger filler ( With servo motor ) / Servo vidalı		
Suitable for / Paketlenebilen ürünler	Coffee, crema, milk powder, whipped cream, starch, powder spices, trim hypnotic, additives and etc... Kahve, krema, süt tozu, krem şanti, nişasta, toz baharat ürünleri, katkı maddeleri, tarım ilaçları vb. toz ürünler		
Filling Range / Gramaj Aralığı	20- 1000 gr	20-2500 gr	500-5000 gr
Shape of the Bag / Paket Tipleri	Pillow bag , Stand up bag	Pillow bag, Stand up bag, Quatro bag / Yastık paket, Oturan ve Quatro paket	
Packaging Speed / Paketleme Hızı	20-50 ppm	20-50 ppm	20-50 ppm
Type of Packaging Material / Ambalaj Malzemesi Cinsi	OPP, CPP, Pet, Alu, Metalize and other laminated films / Opp, Cpp, Pet, Alu, Metalize vb. laminasyonlu malzemeler		
Min. Dimensions of the Bag / Min. Paket Eni ve Boyu	70 x 100 mm	70 x 100 mm	100 x 150 mm
Max. Dimensions of the Bag / Max. Paket Eni ve Boyu	200 x 300 mm	260 x 400 mm	300 x 500 mm
Max. Width of the Film / Max. Bobin Eni	450 mm	550 mm	700 mm
Inner Diameter of the Core / Bobin Makarası İç Çapı	76 mm	76 mm	76 mm
Max . Diameter of the Roll / Max. Bobin Çapı	400 mm	500 mm	500 mm
Dimensions of the Machine / Makine Ebatları	1500 x 2000 x 2600 mm	1700 x 2200 x 2800 mm	1800 x 2200 x 3000 mm
Weight of the Machine / Makine Ağırlığı	750-kg	1.000-kg	1.200-kg
Mechanic Structure / Mekanik Kontrol Sistemi	Pneumatic or servo / Pnömatik veya servo	Pneumatic or servo / Pnömatik veya servo	Pneumatic or servo / Pnömatik veya servo
Pneumatic Systems / Pnömatik Sistem	Festo	Festo	Festo
Control System / Elektrik Sistemi	SIEMENS / OMRON	SIEMENS / OMRON	SIEMENS / OMRON
Electricity Supply & Consumption / Elektrik Beslemesi ve Tüketimi	380 Volt AC / 5 Kwh	380 Volt AC / 6 Kwh	380 Volt AC / 8 Kwh
Air Supply & Consumption / Hava Beslemesi ve Tüketimi	6 bar / 200 Lt / min.	6 bar / 300 Lt / min.	6 bar / 400 Lt / min.



**Vertical Packaging Machines  
With Volumetric Dosing System**

**Volumetrik Dolum Sistemli Dikey Paketleme Makinaları**

Adjustable six telescopic cups controlled by SIEMENS Touch Panel. Suitable for fine granular products. Dimensions and volumes are prepared according to specific requirements.

Suitable for products like, Rice, Beans, Chickpea, Lentils, Sugar, Nuts, Powder Detergent, Coffee Beans, Salt and etc.

Serbest akıcılığı olan taneli-granül haldeki mamüllerin tam otomatik olarak paketlenmesinde kullanılmaktadır. Genellikle bakliyat ürünleri, prinç mercimek makarna, taneli baharat ürünlerinin ambalajlanmasında kullanılır. isteğe bağlı olarak, yastık paket ve oturan paket tiplerinde ambalajlama yapar.

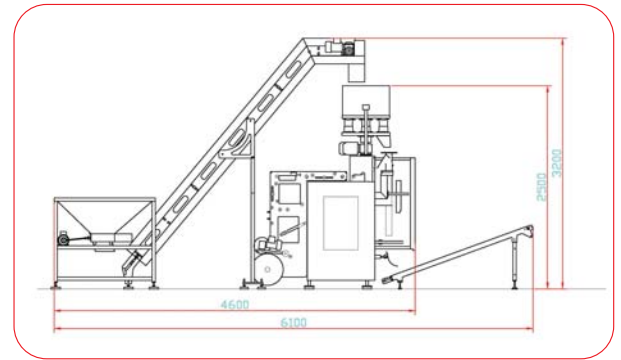

Technical Details Teknik Detay	ODM 100	ODM 400	ODM 600
Filling System / Dolum Sistemi	Volumetric Dosing System / Volumetrik Dolum Sistemi		
Suitable for / Paketlenebilen ürünler	Rice, Beans, Chickpea, Lentils, Sugar, Nuts, Powder Detergent, Coffee Beans, Salt and etc. Bakliyat, baharat, kuruyemiş v.b. taneli ürünler.		
Filling Range / Gramaj Aralığı	20- 1000 gr	20-2500 gr	500-5000 gr
Shape of the Bag / Paket Tipleri	Pillow bag , Stand up bag	Pillow bag, Stand up bag, Quatro bag / Yastık paket, Oturan ve Quatro paket	
Packaging Speed / Paketleme Hızı	20-50 ppm	20-50 ppm	20-50 ppm
Type of Packaging Material / Ambalaj Malzemesi Cinsi	OPP, CPP, Pet, Alu, Metalize and other laminated films / Opp, Cpp, Pet, Alu, Metalize vb. laminasyonlu malzemeler		
Min. Dimensions of the Bag / Min. Paket Eni ve Boyu	70 x 100 mm	70 x 100 mm	100 x 150 mm
Max. Dimensions of the Bag / Max. Paket Eni ve Boyu	200 x 300 mm	260 x 400 mm	300 x 500 mm
Max. Width of the Film / Max. Bobin Eni	450 mm	550 mm	700 mm
Inner Diameter of the Core / Bobin Makarası İç Çapı	76 mm	76 mm	76 mm
Max . Diameter of the Roll / Max. Bobin Çapı	400 mm	500 mm	500 mm
Dimensions of the Machine / Makine Ebatları	1500 x 2000 x 2600 mm	1700 x 2200 x 2800 mm	1800 x 2200 x 3000 mm
Weight of the Machine / Makine Ağırlığı	750-kg	1.000-kg	1.200-kg
Mechanic Structure / Mekanik Kontrol Sistemi	Pneumatic or servo / Pnömatik veya servo	Pneumatic or servo / Pnömatik veya servo	Pneumatic or servo / Pnömatik veya servo
Pneumatic Systems / Pnömatik Sistem	Festo	Festo	Festo
Control System / Elektrik Sistemi	SIEMENS / OMRON	SIEMENS / OMRON	SIEMENS / OMRON
Electricity Supply & Consumption / Elektrik Beslemesi ve Tüketimi	380 Volt AC / 5 Kwh	380 Volt AC / 6 Kwh	380 Volt AC / 8 Kwh
Air Supply & Consumption / Hava Beslemesi ve Tüketimi	6 bar / 200 Lt / min.	6 bar / 300 Lt / min.	6 bar / 400 Lt / min.

**Vertical Packaging Machines  
With Multihead Combination Weighing System**

**Çok Kefeli Elektronik Terazili Dikey Paketleme Makinaları**

Multihead Combination Weighing Systems provide higher speed, high accuracy and reliability. Various models are available depending on specific requirements. Suitable for high production speed with high accuracy. Suitable for products like, All kind of cereals, All kind of nuts, Cookies, Candies, Pasta, Cakes, Fresh & Frozen Fruits and Vegetables, Dried Fruits Snacks, Chips, Cheese Parts and more.

Serbest akıcılığı olan taneli-granül veya kristalize edilmiş toz haldeki mamüllerin tam otomatik olarak paketlenmesinde kullanılmaktadır. Daha çok kuruyemiş, cips, dondurulmuş ürünler, mantı, makarna, bisküvi, çikolata, şekerleme vb. ürünler paketlenmektedir. İsteğe bağlı olarak, yastık paket, oturan paket ve quadro paket tiplerinde ambalajlama yapar.

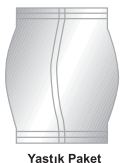
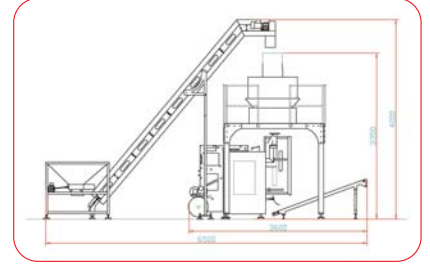

Yastık Paket



Yastık Paket Eurohole Delikli



Yastık Paket Yuvarlak Delikli



Dört Kenar Ütülü Quatro Paket



Oturan paket



Parmak Geçmeli oturan paket



Technical Details Teknik Detay	ODM 100+TW-C / 10	ODM 400+TW-C / 10	ODM 600+TW-C / 10
Filling System / Dolum Sistemi	Ten Head Combination Weighing System / 10 Kefeli Elektronik Terazili		
Suitable for / Paketlenebilen ürünler	Cereals, nuts, dry fruits, chocolate, candy, chips, cookies, pasta, fruit, vegetables, frozen meat, tea etc. Kuruyemiş, şekerleme, bisküvi, çikolata, cipsler, kraker, jelly, makarnalar, çekirdek, kahve vb. ürünler.		
Filling Range / Gramaj Aralığı	20- 1000 gr	20-2500 gr	500-5000 gr
Shape of the Bag / Paket Tipleri	Pillow bag , Stand up bag	Pillow bag, Stand up bag, Quatro bag / Yastık paket, Oturan ve Quatro paket	
Packaging Speed / Paketleme Hızı	20-50 ppm / 20-50 pk./dk.		
Type of Packaging Material / Ambalaj Malzemesi Cinsi	OPP, CPP, Pet, Alu, Metalize and other laminated films / Opp, Cpp, Pet, Alu, Metalize vb. laminasyonlu malzemeler		
Min. Dimensions of the Bag / Min. Paket Eni ve Boyu	70 x 100 mm	70 x 100 mm	100 x 150 mm
Max. Dimensions of the Bag / Max. Paket Eni ve Boyu	200 x 300 mm	260 x 400 mm	300 x 500 mm
Max. Width of the Film / Max. Bobin Eni	450 mm	550 mm	700 mm
Inner Diameter of the Core / Bobin Makarası İç Çapı	76 mm	76 mm	76 mm
Max. Diameter of the Roll / Max. Bobin Çapı	400 mm	500 mm	500 mm
Dimensions of the Machine / Makine Ebatları	1500 x 2000 x 3500 mm	1700 x 2200 x 3500 mm	1800 x 2200 x 3700 mm
Weight of the Machine / Makine Ağırlığı	1.100-kg	1.500-kg	1.700-kg
Mechanic Structure / Mekanik Kontrol Sistemi	Pneumatic or servo / Pnömatik veya servo	Pneumatic or servo / Pnömatik veya servo	Pneumatic or servo / Pnömatik veya servo
Pneumatic Systems / Pnömatik Sistem	Festo	Festo	Festo
Control System / Elektrik Sistemi	SIEMENS / OMRON	SIEMENS / OMRON	SIEMENS / OMRON
Electricity Supply & Consumption / Elektrik Beslemesi ve Tüketimi	380 Volt AC / 5 Kwh	380 Volt AC / 6 Kwh	380 Volt AC / 8 Kwh
Air Supply & Consumption / Hava Beslemesi ve Tüketimi	6 bar / 200 Lt / min.	6 bar / 300 Lt / min.	6 bar / 400 Lt / min.

**Vertical Packaging Machines  
With Multihead Combination Weighing System**

**Çok Kefeli Elektronik Terazili Dikey Paketleme Makinaları**

Multihead Combination Weighing Systems provide higher speed, high accuracy and reliability. Various models are available depending on specific requirements. Suitable for high production speed with high accuracy. Suitable for products like, All kind of cereals, All kind of nuts, Cookies, Candies, Pasta, Cakes, Fresh & Frozen Fruits and Vegetables, Dried Fruits Snacks, Chips, Cheese Parts and more.

Serbest akıcılığı olan taneli-granül veya kristalize edilmiş toz haldeki mamüllerin tam otomatik olarak paketlenmesinde kullanılmaktadır. Daha çok kuruyemiş, cips, dondurulmuş ürünler, mantı, makarna, bisküvi, çikolata, şekerleme vb. ürünler paketlenmektedir. İsteğe bağlı olarak, yastık paket, oturan paket ve quadro paket tiplerinde ambalajlama yapar.

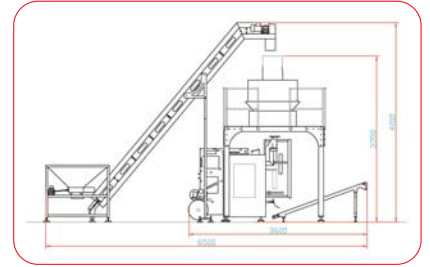

Yastık Paket



Yastık Paket Eurohole Delikli



Yastık Paket Yuvarlak Delikli



Dört Kenar Ütülü Quatro Paket



Oturan paket



Parmak Geçmeli oturan paket



Technical Details Teknik Detay	ODM 100+TW-C / 14	ODM 400+TW-C / 14	ODM 600+TW-C / 14
Filling System / Dolum Sistemi	Fourteen Head Combination Weighing System / 14 Kefeli Elektronik Terazili		
Suitable for / Paketlenebilen ürünler	Cereals, nuts, dry fruits, chocolate, candy, chips, cookies, pasta, fruit, vegetables, frozen meat, tea etc. Kuruyemiş, şekerleme, bisküvi, çikolata, cipsler, kraker, jelly, makarnalar, çekirdek, kahve vb. ürünler.		
Filling Range / Gramaj Aralığı	20- 1000 gr	20-2500 gr	500-5000 gr
Shape of the Bag / Paket Tipleri	Pillow bag , Stand up bag	Pillow bag, Stand up bag, Quatro bag / Yastık paket, Oturan ve Quatro paket	
Packaging Speed / Paketleme Hızı	20-50 ppm (50-80 ppm Servo version) / 20-50 pk./dk. (50-80 pk./dk. Servo Sistemli)		
Type of Packaging Material / Ambalaj Malzemesi Cinsi	OPP, CPP, Pet, Alu, Metalize and other laminated films / Opp, Cpp, Pet, Alu, Metalize vb. laminasyonlu malzemeler		
Min. Dimensions of the Bag / Min. Paket Eni ve Boyu	70 x 100 mm	70 x 100 mm	100 x 150 mm
Max. Dimensions of the Bag / Max. Paket Eni ve Boyu	200 x 300 mm	260 x 400 mm	300 x 500 mm
Max. Width of the Film / Max. Bobin Eni	450 mm	550 mm	700 mm
Inner Diameter of the Core / Bobin Makarası İç Çapı	76 mm	76 mm	76 mm
Max . Diameter of the Roll / Max. Bobin Çapı	400 mm	500 mm	500 mm
Dimensions of the Machine / Makine Ebatları	1500 x 2000 x 3700 mm	1700 x 2200 x 3700 mm	1800 x 2200 x 3900 mm
Weight of the Machine / Makine Ağırlığı	1.400-kg	1.600-kg	1.750-kg
Mechanic Structure / Mekanik Kontrol Sistemi	Pneumatic or servo / Pnömatik veya servo	Pneumatic or servo / Pnömatik veya servo	Pneumatic or servo / Pnömatik veya servo
Pneumatic Systems / Pnömatik Sistem	Festo	Festo	Festo
Control System / Elektrik Sistemi	SIEMENS / OMRON	SIEMENS / OMRON	SIEMENS / OMRON
Electricity Supply & Consumption / Elektrik Beslemesi ve Tüketimi	380 Volt AC / 5 Kwh	380 Volt AC / 6 Kwh	380 Volt AC / 8 Kwh
Air Supply & Consumption / Hava Beslemesi ve Tüketimi	6 bar / 200 Lt / min.	6 bar / 300 Lt / min.	6 bar / 400 Lt / min.

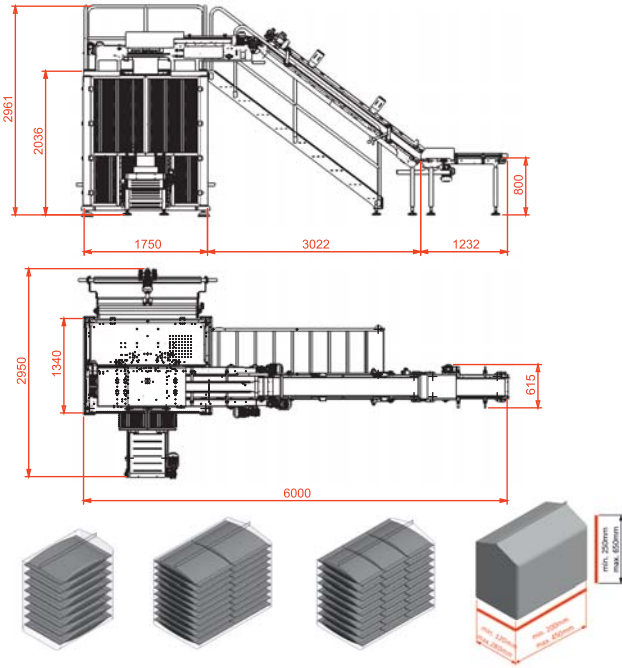

## OBM 130 Full Automatic Bailing Machine Tam Otomatik Balyalama Makinası

The OBM130 is a Full Automatic Baling Machine; which is getting the ready bags that come out of one or several packaging machines, and packs the desired number of this bag into one group of bag. The Bailing Machine it's working from the roll and seal the pack from the top.

### Technical Features Of OBM130 Bailing Machine

- Easy and understandable adjustment and usage possibility thanks to PLC-HMI Interface.
- Fast passing possibility between bale varieties thanks to formula system.
- Easy bale-type change thanks to counting and lining up features with servo-system.
- Bailing possibility of products coming out one or more packing machines.
- Feature of easy integration with packing machines.
- Safety switches complying with CE Standard in all doors.
- Easy bobbin change thanks to bobbin spindle with pneumatic shaft.
- Standard packing capacity with motorized bobbin discharge system.
- Feature of working with/without photocell.
- Full-automatic bobbin centralizing system.
- Using packing capacity in maximum level thanks to "Bobbin goes down" warning system.
- Easy bobbing change thanks to feature of catching package when bobbin finished.

### Advantages Of Full-Automatic Bailing System

- Saving is provided in labour costs thanks to full-automatic working system.
- It decreases packing -line standstills caused from personnel to minimum level since it works as integrated with packing machines and ensures that packing lines work in maximum capacity.
- It guarantees in-bail packet numbers thanks to automatic counting system.
- It decreases packing-material costs since bail package is used as roll.
- In-bail packets can easily be changed as single-row, double-row or triple-row from operator screen.
- In-bail packet numbers or number s of layers being put on top of each other can easily be changed from operator screen.
- In packet inlet conveyors, in-packet air can be evacuated in desired percentage and standard packing is made.

Technical Details Teknik Detay	OBM 130
Bag position system / Paket dizme sistemi	Servo Counter and Distributor System / Servo sayıcı ve dağıtıcı
Suitable products for Bailing / Balya yapılabilen ürünler	All kind of packed products Her tür paketli ürün
Bailing Pack Shape / Balya yapılan paket tipleri	Pillow Bag , Standup Bag / Yastık paket ve oturan paketler
Bailing Speed / Balyalama kapasitesi	4-6 bpm (100-120 ppm. input)
Packaging Material / Balya ambalaj malzemesi cinsi	LDPE - Min. 75 Micron
Width of the Roll & diameter / Balya ambalaj bobini ebatları	Width and Dia 1350 x 400 mm / En ve çap max.1350x400 mm
Pack Sizes / Balya yapılabilen paket ebatları	Min. 120 mm, max. 280 mm
Max. Dimensions of the Bail / Max. Balya ebatları	450*650*200 mm
Each Bag Weight / Balya yapılabilen paket ağırlığı	Min. 200 gr, max 5.000 gr
Maximum Bail Weight / Azami Balya ağırlığı	30 kg.
Dimensions of the Machine( WxLxH) / Makine ebatları	6100*2950*2970 mm
Weight of the Machine / Makine ağırlığı	1.750 kg.
Pneumatic System / Pnömatik sistem	FESTO, SMC
Control System / Kontrol sistemi	SIEMENS, OMRON
Power supply and consumption / Elektrik beslemesi ve tüketimi	380 Volt Ac/ 50 Hz - 6 Kw
Air supply and consumption / Hava beslemesi ve tüketimi	6 Bar – 450 lt/dk.





## OBM 130 Full Automatic Bailing Machine Tam Otomatik Balyalama Makinası

OBM130 Tam otomatik balyalama makinesi; kendi hazırladığı balya poşetine bir veya birkaç paketleme makinesinden çıkan paketleri otomatik olarak alıp sıralayan ve poşet içine istenilen düzen , kat ve sayıda dolduran tam otomatik bir makinedir. Kendi bobin standında rulo halinde bulunan filmi büyük balya poşeti haline getirir içini doldurur ve üstünü kapatır.

### OBM130 Balyalama Makinası Teknik Özellikleri

- PLC-HMI Ara yüzü sayesinde kolay ve anlaşılır ayar ve kullanım imkanı.
- Reçete sistemi özelliği ile balya çeşitleri arasında hızlı geçiş imkanı.
- Servo sistemli sayma ve dizme özelliği ile kolay balya tipi değişimi.
- Bir veya birkaç paketleme makinesinden çıkan ürünleri balyalama imkanı.
- Paketleme makinaları ile kolay entegre edilebilme özelliği.
- Tüm kapılarda CE Standardında güvenlik swiçleri.
- Pnömatik şaftlı bobin mili sayesinde kolay bobin değişimi.
- Motorlu bobin boşaltma sistemi ile standart paketleme kabiliyeti.
- Fotoselli ve fotoselsiz çalışma özelliği.
- Tam otomatik bobin merkezleme sistemi
- Bobin azaldı ikaz sistemi ile paketleme kapasitesinin max. olarak kullanılması.
- Bobin bittiğinde ambalajı yakalama özelliği sayesinde ve kolay bobin değişimi
- Hız kontrollü makine giriş ve balya çıkış konveyörü.

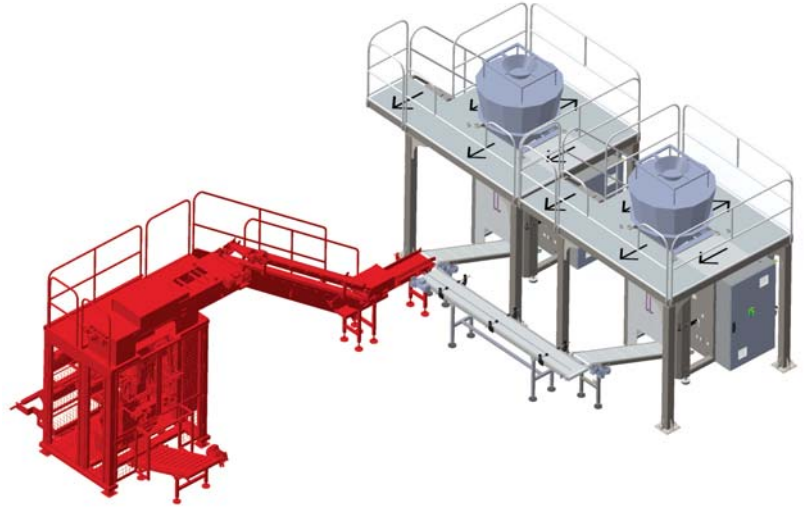

### Tam Otomatik Balyalama Sistemi Avantajları

- Tam otomatik çalışma sistemi sayesinde işçilik maliyetlerinden tasarruf sağlar.
- Paketleme makinaları ile entegre çalıştığı için personel kaynaklı paketleme hattı duruşlarını minimuma indirerek paketleme hatlarının maximum kapasitede çalışmasını sağlar.
- Otomatik sayma sistemi sayesinde balya içi paket adetlerini garanti eder.
- Balya ambalajı rulo olarak kullanıldığından ambalaj malzeme maliyetlerini düşürür.
- Operatör ekranından balya içi paketler tek sıra , çift sıra veya üç sıra olarak kolayca değiştirilebilir.
- Operatör ekranından Balya içi paket sayıları veya üst üste kaç sıra dizileceği kolayca değiştirilebilir.
- Paket giriş konveyörlerinde paket içi hava istenilen oranda alınabilir standart balyalama yapılıdır.

**OKM 500 FULL AUTOMATIC CARTONING MACHINES  
TAM OTOMATİK KOLİLEME MAKİNASI**

The OKM500 It is a Full Automatic Cartonning Machine that packs and sorts automatically one or more packages and fills them into desired arrangement. It automatically getting the carton from the magazine opening, getting the certain shape, closing the bottom flaps, then sealing by tape. The machine also has a vibration system to fit packaging, with automatic adjustment systems that make product and size changes simple and fast, as well as a weighing system that identifies and separates missing or overweight cartons.

**Technical Features Of OKM 500 Full-automatic Cartonning Machine**

- Easy and understandable adjustment and usage possibility thanks to PLC-HMI Interface.
- Possibility of using in short and narrow areas within packing lines thanks to its compact structure.
- Cardboard box carrying magazine with chain system and easy cardboard box feeding possibility.
- The advantage of existing empty package feeding magazine and filled package exit at the same place.
- Using packing-line capacity in maximum level thanks to "Bobbin goes down" warning system.
- Standstill-free working possibility thanks to reserved ready packet area between packet preparing unit and filling unit.
- Optional checkweigher in packet exit in order to control packet weight in gram.
- The advantage of being packets in order within cardboard box by means of under-packet vibration system in cardboard box filling unit.
- Fast passing possibility between different bale sizes thanks to formula system.
- Easy in-cardboard box layout-type change thanks to counting and lining up features with servo-system.
- Automatic bailing possibility of products coming out one or more packing machines.
- Feature of easy integration with packing machines.
- Electromagnetic safety switches complying with CE Standard in all doors.
- Speed-controlled machine inlet conveyor.

**Advantages Of Full-Automatic Cartonning System**

- Saving is provided in labour costs thanks to full-automatic working system.
- It decreases packing -line standstills caused from personnel to minimum level since it works as integrated with packing machines and ensures that packing lines work in maximum capacity.
- It guarantees in-packing packet numbers thanks to automatic counting system.
- In-packing packets can easily be changed as single-row, double-row or triple-row from operator screen.
- In-packing packet numbers or number s of layers being put on top of each other can easily be changed from operator screen.
- In packet inlet conveyors, in-packet air can be evacuated in desired percentage and standard packing is made.

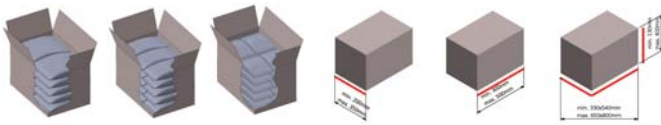
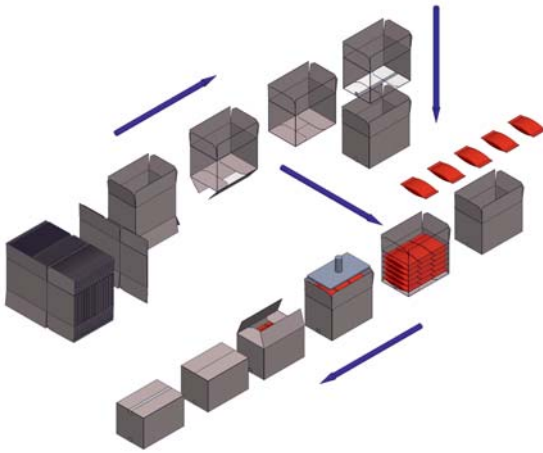

Technical Details / Teknik Detay	OKM 500
Carton Filling and Stacking System / Koliye Dolum ve dizme sistemi	Servo Counter and Distributor System / Servo sistemli sayıcı ve dağıtıcı
Packed product / Koli yapılan ürünler	All kind of packed products Her türlü paketleniş ürün kutulanabilir
Cartoning combinations & quantity / Kollleme Kombinasyonu ve adetleri	Depends of the product dimensions can be adjust / Paket ebadına göre değişken ayarlanabilir
Cartoning / Infeed capacity / Kollleme / Besleme kapasitesi	10-12 Carton / minute / 110-120 packs per minute infeed capacity 10-12 Koli / dakika / 110-120 paket/dakika giriş kapasitesi /
Carton Material / Karton Ambalaj malzemesi cinsi	Single or double wavy corrugated / Tek veya çift dalgalı oluklu mukavva
Width of Carton Package / Koli içi paket Genişliği	Min. 120 mm. / Max. 280 mm
Height of Carton Package / Koli içi paket Boyu	Min. 120 mm. / Max. 450 mm
Opened Carton Dimensions / Açık koli ölçüleri	Min 540x330 mm. / Max.800x650 mm
Closed Carton Dimensions / Kapalı Koli ebatları	Width Min. 200x300 mm Length Min.350 max. 350 mm / En Min. 200x300 mm Boyu Min.350 max. 350 mm
Carton heights / Koli yükseklikleri	Min. 130 mm – Max 400 mm
Cartons Storage Sizes / Koli yükleme magazini	140 cm
Dimensions of the Machine / Makine ebatları	1572x7400x2500 mm
Weight of the Machine / Makine ağırlığı	2.450 kg.
Pneumatic System / Pnömatik sistem	FESTO, SMC
Electric System / Elektrik sistemi	SIEMENS, OMRON
Power supply and consumption / Elektrik beslemesi ve tüketimi	12 Kwh
Air supply and consumption / Hava beslemesi ve tüketimi	6 Bar, 550 lt/dk. / 6 Bar, 550 lt/min.



## OKM 500 FULL AUTOMATIC CARTONING MACHINES TAM OTOMATİK KOLİLEME MAKİNASI

OKM500 Tam otomatik Kolileme makinesi; kendi hazırladığı kolilere bir veya birkaç paketleme makinesinden çıkan paketleri otomatik olarak alıp sıralayan ve koli içine istenilen düzen, kat ve sayıda dolduran tam otomatik bir makinedir. Kendi mağazisinde açık pozisyonda istiflenmiş halde bulunan kolileri otomatik olarak alır, açar, altını koli bandı ile yapıştırır, içini doldurur ve üstünü koli bandı ile kapatır. Makine paketlerin koli içine sığabilmesi için vibrasyon sistemlerine, ürün ve ebat değişimlerini basit ve hızlı hale getiren otomatik ayar sistemlerine ve de eksik yada fazla gramajlı kolileri belirleyip ayıran tartım sistemine de sahiptir.

### OKM 500 Kolileme Makinası Teknik Özellikleri

- PLC-HMI Ara yüzü sayesinde kolay ve anlaşılır ayar ve kullanım imkanı.
- Kompak yapısı ile paketleme hatlarında kısa ve dar alanlarda kullanım imkanı
- Zincir sistemli koli taşıma magazini ve kolay koli besleme imkanı.
- Boş koli besleme magazini ile dolu koli çıkışının aynı yerde olması avantajı.
- Koli azaldı ikazı ile paketleme hattı kapasitesinin max. olarak kullanılması.
- Koli hazırlama ünitesi ile dolum ünitesi arasında rezerv hazır koli alanı ile duruşsuz çalışma imkanı
- Opsiyonel olarak koli çıkışında koli gramajı kontrolü yapmak için checkweigher.
- Koli dolum ünitesinde vibrasyon ile paketlerin koli içinde düzenli olması avantajı.
- Reçete sistemi özelliği ile farklı koli ebatları arasında hızlı geçiş imkanı.
- Servo sistemli sayma ve dizme özelliği ile kolay koli içi yerleşim şekli değişimi.
- Birkaç paketleme makinasından çıkan ürünleri otomatik olarak kolileme imkanı.
- Paketleme makinaları ile kolay entegre edilebilme özelliği.
- Tüm kapılarda CE Standardında elektromanyetik güvenlik anahtarları
- Hız kontrollü makine giriş konveyörü.

### Tam Otomatik Kolileme Sistemi Avantajları

- Tam otomatik çalışma sistemi sayesinde işçilik maliyetlerinden tasarruf sağlar.
- Paketleme makinaları ile entegre çalıştığı için personel kaynaklı paketleme hattı duruşlarını minimuma indirerek paketleme hatlarının maximum kapasitede çalışmasını sağlar.
- Otomatik sayma sistemi sayesinde koli içi paket adetlerini garanti eder.
- Operatör ekranından koli içi paketler çift sıra, üç sıra veya 4 sıralı olarak kolayca değiştirilebilir.
- Operatör ekranından koli içi paket sayıları veya üst üste kaç sıra dizileceği kolayca değiştirilebilir.
- Paket giriş konveyörlerinde paket içi hava istenilen oranda alınabilir standart kolileme yapılır.

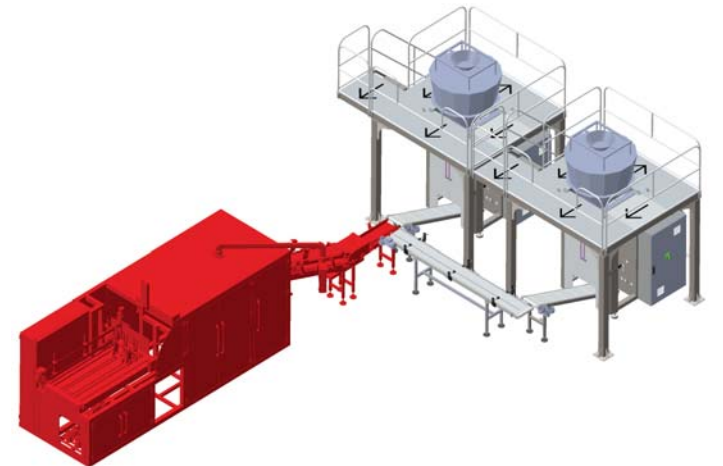
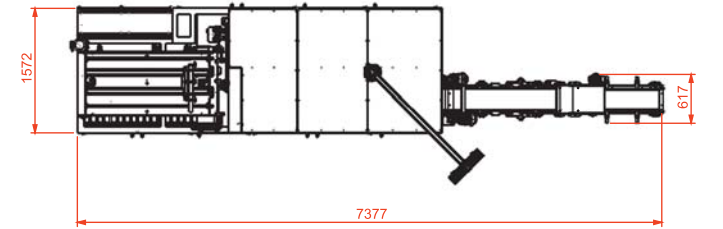
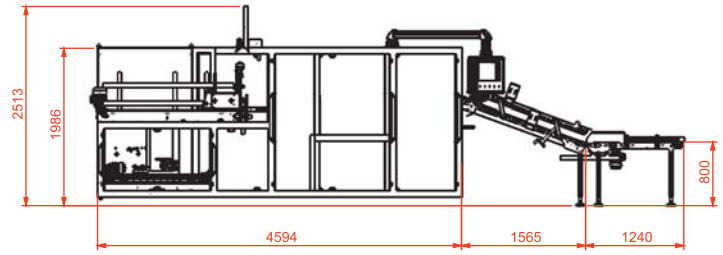



**HT 85-200** Doypack Type Packaging Machine  
Doypak Tip Paketleme Makinesi

HT /85-200 is a Full Automatic Stand Up Pouch Packaging Machine which works with pre-made pouches. HT /85-200 takes pre-made pouches from Pouch Feeding Section and prepares for Filling Unit then fills and seals automatically. HT /85-200 can pack Powder and Granule products like Coffee, Milk Powder, Nuts, Spices, Candies and other similar products by using Auger Filler , Volumetric Filler or Electronic Weighers. HT /85-200 can also pack Liquid or Semi Liquid products like Juice, Tomato Paste, Ketchup, Mayonnaise, Honey by using Liquid Filler. HT /85-200 can use pre-made Pouches with Zip , Eurohole or Spout optionally.

Tam otomatik üç tarafı kapalı hazır paketlere çalışan Stand up Pouch paketleme makinasıdır. Yüksek paketleme hızı istenen işletmelerde kahve, süt tozu, krema, kuruyemiş, baharat, şekerleme, çikolata gibi kuru ürünler, meyve suyu, salça, ketçap, mayonez, bal, pekmez gibi aseptik dolum gerektiren ürünlerin tam otomatik olarak ambalajlanmasında kullanılır. Askı delikli, zipperli hazır torbalarda çalışabildiği gibi koruyucu gaz sistemi de opsiyonel olarak kullanılabilir. Makinaya toz ürünler için vidalı dolum sistemi taneli ürünler için volümetrik, linear, çok kefeli elektronik terazi sistemi ve sıvı ürünler için likit dolum sistemi akuple edilebilmektedir.

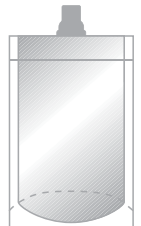
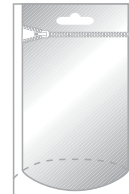

4 Side Sealed

Stand up Pouch  
With Round Hole

Stand up Pouch  
With Eurohole & Zip

Stand up Pouch  
With Spout

Technical Details Teknik Detay	HT 85-200
Filling System / Dolum Sistemi	Electronic weighing system, Volumetric, Auger filler, liquid pump / Volumetrik, Vidalı Çok kefeli terazili, Likit pompalı
Suitable for / Paketlenebilen ürünler	Nuts, sweets, spices, chips, cookies, sweets, detergents, chemical products, etc. Kuruyemiş, çikolata, baharat, cips, bisküvi, kraker, jelly, draje vb. gıda ürünleri deterjanlar, kimyasal katkı maddeleri vb. ürünler
Filling Range / Gramaj Aralığı	20 - 500 gr
Shape of the Bag / Paket Tipleri	3 or 4 side sealed, Doypack type (With or without zipper) / 3 veya 4 Kenar yapışık hazır paketler ve hazır Doypack paketler
Packaging Speed / Paketleme Hızı	20-40 ppm / 20-40 pak/dakika
Type of Packaging Material / Ambalaj Malzemesi Cinsi	OPP, CPP, PET, AL, and other all kind of laminated film / Opp, Cpp, Pet, Metalize, Alüminyum vb. laminasyonlu malzemeler
Min. Dimensions of the Bag / Min. Paket Eni ve Boyu	85 x 140 mm
Max. Dimensions of the Bag / Max. Paket Eni ve Boyu	200 x 280 mm
Max. Width of the Film / Max. Bobin Eni	-
Inner Diameter of the Core / Bobin Makarası İç Çapı	-
Max. Diameter of the Roll / Max. Bobin Çapı	-
Dimensions of the Machine / Makine Ebatları	2900 x 1500 x 1500 mm
Weight of the Machine / Makine Ağırlığı	1.050-kg
Mechanic Structure / Mekanik Kontrol Sistemi	Mechanical cam / Mekanik kamlı
Pneumatic Systems / Pnömatik Sistem	Festo
Control System / Elektrik Sistemi	SIEMENS
Electricity Supply & Consumption / Elektrik Beslemesi ve Tüketimi	380 Volt AC / 7 Kw
Air Supply & Consumption / Hava Beslemesi ve Tüketimi	6 bar / 300 Lt / min.



**DB/S 70-105** Doypack Type Packaging Machine  
Doypak Tip Paketleme Makinesi

DB/S 70-105 is Full Automatic Stand Up Pouch Packaging Machine which works from Roll to Final Pack. Related to the product, gramage and dosing unit, DB / 72-120 can work fastly to pack Coffee, Milk Powder, Nuts, Candies, Biscuits, Spices and other Powder And Granule Products. Additionally DB/ 72-120 can pack Liquid Or Semi Liquid Products like Tomato Paste, Juice, Ketchup, Mayoise, Honey and other similar products with Zip, Eurohole, Or Spout optionally. DB / 72-120 uses Auger Dosing Unit for Powder Products, Volumetric or Electronic Weigher for Granule Products and for Liquid products Filling Unit.

Tam otomatik bobinden çalışan Stand up Pouch paketleme makinasıdır. Yüksek paketleme hızı istenen işletmelerde kahve, süt tozu, krema, kuruyemiş, baharat, şekerleme, çikolata gibi kuru ürünler, meyve suyu, salça, ketçap, mayonez, bal, pekmez gibi aseptik dolum gerektiren ürünlerin tam otomatik olarak ambalajlanmasında kullanılır. Askı delikli, zipperli hazır torbalarda çalışabildiği gibi koruyucu gaz sistemi de opsiyonel olarak kullanılabilir. Makinaya toz ürünler için vidalı dolum sistemi taneli ürünler için volumetrik, linear, çok kefeli elektronik terazi sistemi ve sıvı ürünler için likit dolum sistemi akuple edilebilmektedir.

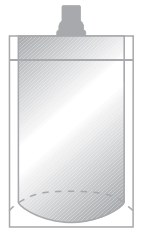

4 Side Sealed

Stand up Pouch  
With Round Hole

Stand up Pouch  
With Eurohole & Zip

Stand up Pouch  
With Cap

Technical Details Teknik Detay	DB/S 70-105
Filling System / Dolum Sistemi	Electronic weighing system, Volumetric , Auger filler, liquid pump / Volumetrik, Vidalı Çok kefeli terazi, Likit pompalı
Suitable for / Paketlenebilen ürünler	Nuts, sweets, spices, chips, cookies, sweets, detergents, chemical products, etc. Kuruyemiş, çikolata, baharat, cips, bisküvi, kraker, jelly, draje vb. gıda ürünleri deterjanlar, kimyasal katkı maddeleri vb. ürünler
Filling Range / Gramaj Aralığı	20 - 500 gr
Shape of the Bag / Paket Tipleri	3 or 4 side sealed, Doypack type (With or without zipper) / 3 veya 4 Kenar yapışık hazır paketler ve hazır Doypack paketler
Packaging Speed / Paketleme Hızı	30-70 ppm / 30-70 pak/dakika
Type of Packaging Material / Ambalaj Malzemesi Cinsi	OPP, CPP, PET, AL, and other all kind of laminated film / Opp, Cpp, Pet, Metalize, Alüminyum vb. laminasyonlu malzemeler
Min. Dimensions of the Bag / Min. Paket Eni ve Boyu	85 x 140 mm
Max. Dimensions of the Bag / Max. Paket Eni ve Boyu	200 x 280 mm
Max. Width of the Film / Max. Bobin Eni	660 mm
Inner Diameter of the Core / Bobin Makarası İç Çapı	76 mm
Max . Diameter of the Roll / Max. Bobin Çapı	550 mm
Dimensions of the Machine / Makine Ebatları	6400 x 1500 x 1600 mm
Weight of the Machine / Makine Ağırlığı	2.200-kg
Mechanic Structure / Mekanik Kontrol Sistemi	Servo control / Servo kontrollü
Pneumatic Systems / Pnömatik Sistem	Festo
Control System / Elektrik Sistemi	BOSCH REXROTH
Electricity Supply & Consumption / Elektrik Beslemesi ve Tüketimi	380 Volt AC / 12 Kwh
Air Supply & Consumption / Hava Beslemesi ve Tüketimi	6 bar / 300 Lt / min.



## KDM 800

### ROTARY JAR FILLING MACHINE ROTARY KAVANUZ DOLUM MAKİNASI

KDM800 Full-automatic rotary jar filling machine has been used in full-automatic untouched packing of food, chemical, cosmetics, medicine etc. products into cardboard, plastic and tin boxes hygienically. The filling products can be granule, powder and liquid form. Filling system changes according to product structure. Units like cleaning system for jar, jar-cap closing system, safety band application system, metal detectors, labeling systems can be used optionally in full-automatic rotary filling line.

KDM800 Tam otomatik rotary kavanoz dolum makinası gıda, kimya, kozmetik, ilaç vb. ürünlerin cam, pet, ve teneke kutular içine el değmeden hijyenik olarak tam otomatik paketlenmesinde kullanılmaktadır.

Dolumu yapılan ürünler, granül, toz ve sıvı formunda olabilir. Ürün yapısına göre dolum sistemi değişmektedir. Tam otomatik rotary dolum hattında opsiyonel olarak, kavanoz için temizleme sistemi, kavanoz kapak kapatma sistemi, emniyet bandı uygulama sistemi, metal dedektörler, etiketleme sistemleri gibi üniteler kullanılabilir.

## LDM 400 LINEAR JAR & CUP FILLING MACHINE LINEAR KAVANUZ VE KUTU DOLUM MAKİNASI

LDM400 Full-automatic box filling machine has been used in full-automatic untouched packing of food, chemical, cosmetics, medicine etc. products into cardboard, plastic and tin boxes hygienically. The filling products can be granule, powder and liquid form. Filling system changes according to product structure. Units like cleaning system for box, box-cap closing system, metal detectors, labeling systems can be used optionally in full-automatic linear filling line.

LDM400 Tam otomatik kutu dolum makinası gıda, kimya, kozmetik, ilaç vb. ürünlerin karton, cam, pet ve teneke kutular içine el değmeden hijyenik olarak tam otomatik paketlenmesinde kullanılmaktadır. Dolumu yapılan ürünler, granül, toz ve sıvı formunda olabilir. Ürün yapısına göre dolum sistemi değişmektedir. Tam otomatik lineer dolum hattında opsiyonel olarak, kutu için temizleme sistemi, kutu kapak kapatma sistemi, metal dedektörler, etiketleme sistemleri gibi üniteler kullanılabilir.



Technical Details Teknik Detay	Automatic Rotary Jar & Cup Filling Machine	Automatic Linear Jar & Cup Filling Machines
Filling Systems / Dolum Sistemleri	• Servo Auger Filler for Powders • Multihead Weighers for granular products • Liquid & Paste Fillers	
Products / Ürünler	Spices, Salt, Coffee beans & powders, crema, chemicals, chewing gum, nuts, candies, cookies, chocolates, snacks, cosmetic products, honey, jam, chocolate paste and similar all kind of powder, granule, liquid and paste products	Baharatlar, tuz, toz ve granül kahve, krema, bebe maması, süt tozu, kimyasallar, sakız, kuruyemiş, şekerleme, kurabiye, çikolata, kraker, bal, pekmez reçel, tırm ilaçları, Kozmetik kremler, ilaç ve benzeri her çeşit toz, taneli ve sıvı ürünler
Filling Range / Dolum Aralığı	10- 2000 gr	
Type of Package / Ambalaj Tipi	Glass, PET, Tin Cans, Polistiren, Carton Cups and Jars	Cam ve pet kavanozlar, teneke ve polistiren kutular.
Packaging Speed / Paketleme Hızı	20-60 cpm	20-60 kap/dak.
Cup / Box dimensions / Kavanoz / kutu ölçüleri	Diameter / Width 40-160 mm - Height 80 - 280 mm	Çap / En 40-160 mm - Yükseklik 80-280 mm
Infeed Turn Table / Giriş Döner tabla çapı	Min 600 mm – Max 1100 mm	
Optional Equipments / Tamamlayıcı ekipmanlar	Jar & Cup Cleaning System Induction sealing system, Automatic Labelling, Capping & Cap Feeding, Security Sleeve applicator, Sleeve Tunnel, date & code printer	Kavanoz içi temizleme sistemi, İndüksiyon yapıştırma sistemi, etiketleme makinası, kapak besleme ve kapatma sistemi, sleeve emniyet bandı takma sistemi ve sleeve emniyet bandı tüneli, printer
Dim. of the Machine / Makine ebatları	4800*2100*4100 mm	3600*1600*4100 mm
Weight of the Machine / Makine ağırlığı	1.600 kg	1.200 kg
Pneumatic / Pnömatikler	FESTO / SMC	
Control System / Kontrol Sistemi	SIEMENS /OMRON PLC	
Electricity / Elektrik	380 Volt AC / 8 Kwh	380 Volt AC / 6 Kwh
Air / Hava	6 bar / 100 Lt/min.	



## PNKS SH 60/50 Shrink Wrapping Machines Shrink Ambalaj Makinesi

### Shrink Wrapping Machines

For packaging jars, bottles, cans, boxes, wooden & plastic parts, metal parts, furnitures, toys and etc. One by one or group packaging. The Machine is produced such as Semi-automatic, full automatic, front-feed and/or full automatic side-feed models. Printed or transparent PE, PVC or poliolefin packaging materials are suitable for wrapping the desired products.

### Shrink Ambalaj Makinaları

Koli, karton tava, teneke kutu, cam şişe, kavanoz, plastik şişe, pet şişe içindeki gıda, kimya, kozmetik, tekstil ve kirtasiye ürünlerinin baskılı veya baskısız polietilen (PE), PVC veya Poliolefin folyo ile sarılarak ambalajlanmasında kullanılmaktadır. Yarı otomatik, önden beslemeli tam otomatik, yandan beslemeli tam otomatik olarak değişik tiplerde imal edilmektedir.

Ayrıca panel radyatör üretim fabrikalarında kullanılmak üzere tam otomatik radyatör indirme makinası, tam otomatik balonlu naylon sarma makinası ve tam otomatik radyatör shrink makinası olmak üzere radyatör ambalaj hattı olarak imal edilmektedir.



Technical Details Teknik Detay	PNKS SH 60/50
Packaging Material / Ambalaj Malzemesi	PE, PVC and other shrinkable materials / PE, PVC, ve diğer Shrink Malzemeleri
Max.Width / Ambalaj Eni	650 mm
Max. Pack Dimension / Paket Ebatları (Max.)	500x1200x450 mm
Conveyor Speed / Konveyör Hızı	Can be calibrated between 1,7 - 4,2 mt/dk. / 1,7 - 4,2 m/dk. arasında ayarlanabilir
Type of Conveyor / Konveyör Sistemi	Grid band or Bar / Hasır Bant veya Çubuklu
Sealing Jaw / Çene Tipi	Teflon Coated hot sealing bar / Teflon Kaplı Sıcak Çene
Packing Speed / Kapasite	7-12 ppm. / 7-12 Pk.-Pk/dk.
Electricity Supply / Elektrik İhtiyacı	3x380 Volt AC / N / PE
Electricity Consumption / Elektrik Tüketimi	8 Kw / h
Air Supply / Hava İhtiyacı	6 Bar
Air Consumption / Hava Tüketimi	100 Lt. / min.
Dimensions of the Machine / Makina Ebatları	1300x3800x2100 mm
Weight of the Machine / Makina Ağırlığı	900 kg.



**MINI JUMBO**

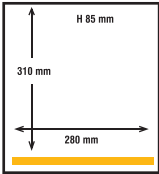

- Capacity pump 004 m3/h
- Machine cycle 25-60 sec.
- Dimensions 330 x 450 x 295 mm
- Voltage 230V-1-50Hz
- Other voltages are available
- Power 0,3 - 0,4 KW



**JUMBO 30**

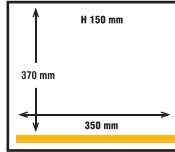

- Capacity pump 8 m3/h
- Machine cycle 20-40 sec.
- Dimensions 525 x 450 x 370 mm
- Voltage 230V-1-50 Hz
- Other voltages are available
- Power 0,40 KW



**BOXER 42**

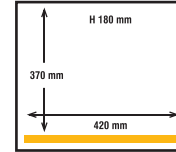

- Capacity pump 021 m3/h
- Machine cycle 15-35 sec.
- Dimensions 490 x 525 x 430 mm
- Voltage 230V-1-50Hz
- Other voltages are available
- Power 0,75 - 1,0 KW



**LYNX 42**

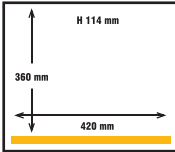

- Capacity pump 016 m3/h
- Machine cycle 15-30 sec.
- Dimensions 534 x 480 x 396 mm
- Voltage 230V-1-50 Hz
- Other voltages are available
- Power 0,7 KW
- Direct thermal Label printer (Zebra Technologies)
- Programmable content of label (production / expiry date, product name, storage temperature, gas mixtures, etc.)
- Possibility of multiple labels / cycle
- Backing foil remover



**TOUCAN 42**

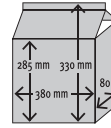
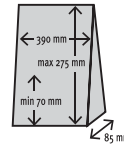

- Capacity pump 21 m3/h
- Machine cycle 15-30 sec.
- Dimensions 480 x 745 x 650 mm
- Voltage 230V-1-50 Hz
- Other voltages are available
- Power 0,7 KW



**MARLIN 52**

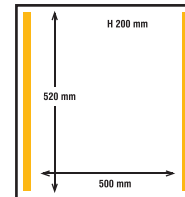

- Capacity pump 063 m3/h
- Machine cycle 15-40 sec.
- Dimensions 700 x 690 x 1030 mm
- Voltage 400V-3-50Hz
- Other voltages are available
- Power 2,4 - 3,5 KW



Technical Details Teknik Detay	MINI JUMBO	JUMBO 30	BOXER 42	LYNX 42	TOUCAN 42	MARLIN 52
Types of models and chamber / Model ve hazne tip	Table model / Tezgah üstü tek hazneli					Floor model / Koridor Tip
Pump capacity / Vakum pompası	4 M3/h – BUSCH	8 M3/h – BUSCH	21 M3/h – BUSCH	16 M3/h – BUSCH	21 M3/h – BUSCH	63 M3/h – BUSCH
Machine dimensions / Makine ebatları	330*450*295 mm	525*450*370 mm	520*480*450 mm	534*480*396 mm	480*490*780 mm	690*700*1030 mm
Chamber Dimensions / Hazne içi ebatları	280*310*85 mm	370*350*150 mm	420*370*180 mm	360*420*114 mm	85*390*275 mm	520*500*200 mm
Seal bar length / Yapıştırma çene uzunluğu	28 cm double seal	35 cm double seal	42 cm double seal	42 cm double seal	42 cm double seal	52 cm double seal
Number of sealing bar / Yapıştırma çene sayısı	1 unit / 1 adet	1 unit / 1 adet	1 unit / 1 adet	1 unit / 1 adet	1 unit / 1 adet	2 unit / 2 adet
Type of packing material / Ambalaj malzemesi cinsi	PA+PE , PET+PE, PET+AL+PE					
Machine cycle / Vakumlama süresi	15-35 sec.	20-40 sec.	15-35 sec.	15-40 sec.	15-35 sec.	15-35 sec.
Voltage / Elektrik beslemesi	0,4 kw/h - 220 Volt A.C	0,4 kw/h - 220 Volt A.C	0,75 kw/h - 220 Volt A.C	0,7 kw/h - 220 Volt A.C	1 kw/h - 220 Volt A.C	2,4 kw/h - 220 Volt A.C
Operational control functions / Kontrol paneli	digital control	digital control	digital control	lcd screen	digital control	digital control
Gas-flush / Gaz basma ünitesi	-	-	optional	optional	optional	optional
Soft-air / Soft air modu	-	-	standart	standart	standart	standart
Pump cleaning mode / Pompa temizlik modu	Available	Available	standart	standart	standart	standart
Printer / Printer ünitesi	-	-	-	-	-	-
Sensor control / Sensör kontrol	-	-	optional	optional	optional	optional
Liquid control / Likit kontrol sistemi	-	-	optional	optional	optional	optional
Cutting package / Paket kesme	optional	optional	optional	optional	optional	optional
Bi-Active Seal / Biactive seal	optional	optional	optional	optional	optional	optional



## FALCON 2-70

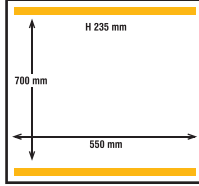

- Capacity pump 100 m3/h
- Machine cycle 15-40 sec.
- Dimensions 1260 x 1010 x 1070 mm
- Voltage 400V-3-50Hz
- Other voltages are available
- Power 3,5 - 4,5 KW



## POLAR 2-50

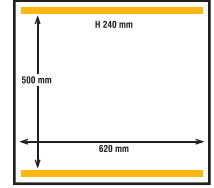

- Capacity pump 100 m3/h
- Machine cycle 15-40 sec.
- Dimensions 1545 x 900 x 1175 mm
- Voltage 400V-3-50Hz
- Other voltages are available
- Power 3,5 - 5,3 KW

## DT 60 DIPTANK

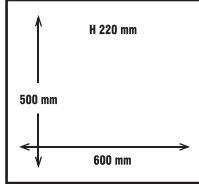

- Cycle time: 3-5 seconds
- Maximal loading capacity: 60 kg
- Voltage: 400V-3-50 Hz
- Digital temperature control
- Hydraulic movement
- Isolation balls against evaporation



Technical Details Teknik Detay	DT 60 DIPTANK
Types of models and chamber / Model ve hazne tip	Floor model / Koridor tip tekerlekli tek hazne
Movement / Havuz asansör sistemi	Hydraulic / Hidrolik
Machine dimensions / Makine ebatları	740*770*1055 mm
Tank dimensions / Hazne içi ebatları	500*600*220 mm
Maximal loading capacity / Max. ürün yüklemesi	60 kg.
Type of packing material / Ambalaj malzemesi cinsi	Vacuum bags dedicated for Shrink / Shrink yapmaya uygun vakum torbaları
Cycle time / Shrinkleme süresi	3-5 sn.
Voltage / Elektrik beslemesi	9,0 kw/h 380 Volt A.C
Operational control functions / Kontrol paneli	Digital temperature control / Dijital ısı ve zaman kontrolü
Temperature control system / Su ısı kontrol sistemi	PID control / PID kontrol
Isolation balls against evaporation / Isı izolasyon topları	Standart



Technical Details Teknik Detay	FALCON 2-70	POLAR 2-50
Types of models and chamber / Model ve hazne tip	Single and double chamber floor models / Koridor tip çift hazneli tekerlekli	
Pump capacity / Vakum pompası	100 M3/h – BUSCH	100 M3/h – BUSCH
Machine dimensions / Makine ebatları	1010*1260*1070 mm	900*1545*1175 mm
Chamber Dimensions / Hazne içi ebatları	550*700*235 mm	500*620*240 mm
Seal bar length / Yapıştırma çene uzunluğu	55 cm double seal	62 cm double seal
Number of sealing bar / Yapıştırma çene sayısı	4 unit / 4 adet	4 unit / 4 adet
Type of packing material / Ambalaj malzemesi cinsi	PA+PE, PET+PE, PET+AL+PE	
Machine cycle / Vakumlama süresi	15-35 sec.	15-35 sec.
Voltage / Elektrik beslemesi	3,0-5,0 kw/h - 220 Volt A.C	3,5-5,3 kw/h - 220 Volt A.C
Operational control functions / Kontrol paneli	digital control	digital control
Gas-flush / Gaz basma ünitesi	optional	optional
Soft-air / Soft air modu	-	standart
Pump cleaning mode / Pompa temizlik modu	standart	standart
Printer / Printer ünitesi	-	-
Sensor control / Sensör kontrol	optional	optional
Liquid control / Likit kontrol sistemi	optional	optional
Cutting package / Paket kesme	optional	optional
Bi-Active Seal / Biactive seal	optional	optional

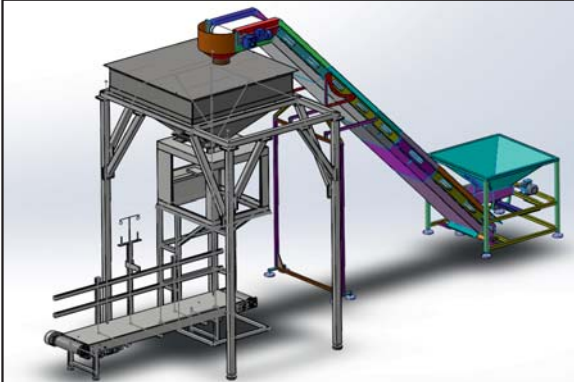

Sack filling machine  
Çuval dolum makinaları



Box-jar filling machine  
Kutu kavanoz dolum makinaları



Multiheadweigher  
Çok kefeli elektronik teraziler



Multiheadweigher  
Çok kefeli elektronik teraziler



Volumetric Filling system  
Volumetrik dozajlayıcılar



Electronic Weigher with servo control  
Servo kontrollü elektronik teraziler



Metal Detector Round Hole  
Boğaz tipi metal dedektör



Metal Detector Round Hole  
Boğaz tipi metal dedektör



Screw auger filler  
Vidalı dozajlayıcı



Thermal transfer Printers



Feeding elevator with auger screw  
Vidalı besleme elevatörü



Feeding elevator with band  
Bantlı besleme elevatörü



Output conveyör band  
Çıkış konveyör bandı



Forming tubes  
Yaka boru takımları



Metal Dedector Conveyor Type  
Bant tipi metal dedektör



Checkweighers  
Gramaj kontrol makinaları

For Online Catalog  
Online Katalog İin



**tam•taş**  
packaging machinery

**TAMTAŞ MAKİNA SANAYİ VE TİCARET A.Ş.**

İkitelli Osb. Mah. Heskoop D Blok Sok. Heskoop Sitesi D Blok No: 30-31-32

34490 Başakşehir / İstanbul / Türkiye

Tel : +90 212 554 22 66 pbx

Fax: +90 212 554 22 69

**tamtas@tamtas.net**



All specifications are subject to changing without notice.

**www.tamtas.net**